



TSic 206/203/201/ 306/303/301

Temperature Sensor IC

For a fully calibrated and accurate low power temperature measurement

Benefits & Characteristics

- Fully calibrated
- Custom calibration and assembly available
- Very low power consumption
- Excellent long-term stability
- Accuracy of ± 0.3 K (TSic 30x), ± 0.5 K (TSic 20x)
- Accuracy range of 80 K can be shifted (default: +10 °C to +90 °C)
- Available with digital, analog and ratiometric output signal

Illustration¹⁾

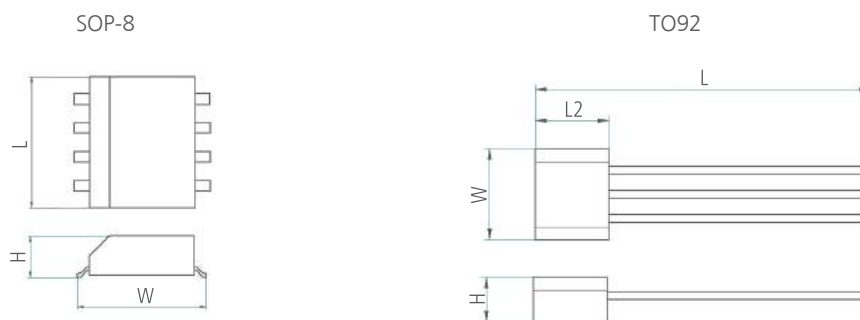

1) For actual size, see dimensions

Technical Data

Dimensions (L / L2 x W x H in mm): ²⁾	4.93 x 5.99 x 1.63 (SOP-8) 17.30 / 3.81 x 4.57 x 2.3 (TO92)
Operating temperature range:*	-50 °C to +150 °C (-47 °C to +147 °C guaranteed)
Accuracy:*	TSic 20x ± 0.5 K in the range of +10 °C to +90 °C (other ranges on request) TSic 30x ± 0.3 K in the range of +10 °C to +90 °C (other ranges on request)
Resolution:*	0.1 K
Sampling rate:*	10 Hz
Supply current:	typ. 30 μ A at 25 °C and $V_{dd} = 3.3$ V for minimal self-heating
Packaging:*	SOP-8 or TO92 (other packaging on request)
Output signal:	Analog (TSic xx1), ratiometric (TSic xx3), digital (TSic xx6) - see application note ATTSic_E

* Customer-specific alternatives available

²⁾ For tolerances, see Application Note



Pin Assignment

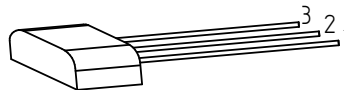
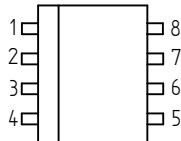

	Pin 1	Pin 2	Pin 3	Pin 4
SOP-8 (3, 5, 6, 7 and 8 not connected)	V_{dd} Supply voltage (3 V to 5.5 V)	Signal		GND
TO92	GND	Signal	V_{dd} Supply voltage (3 V to 5.5 V)	

Absolute maximal ratings

	Min	Max
Supply voltage (V_{dd})	-0.3 V	6 V
Voltages to analog I/O – Pins (V_{SIG} , V_{GND})	-0.3 V	$V_{dd}+0.3$ V
Storage temperature range (T_{STOR})	-20 °C	+80 °C
Non-operating temperature range	-50 °C	+150 °C

Operating conditions

	Min	Typ	Max
Supply voltage to GND (V_{dd})	2.97 V	5 V	5.5 V
Supply current ($I_{V_{dd}}$) at $V_{dd} = 3.3$ V, RT	25 μ A	30 μ A	60 μ A
Operating temperature range (T_{amb})	-50 °C		+150 °C
Output load capacitance (C_L)			15 nF
External capacitance between V_{dd} and GND ¹⁾	100 nF (recommended)		
Output load resistance between signal and GND (or V_{dd})	47 k Ω		

¹⁾ Recommended as close to TSic V_{dd} and GND-Pins as possible

Temperature accuracies²⁾

	TSic 20x	TSic 30x
T1: +10 °C to +90 °C	± 0.5 K	± 0.3 K
T2: -20 °C to +110 °C	± 1 K	± 0.6 K
T3: -50 °C to +150 °C	± 2 K	± 1.2 K

²⁾ The sensor is calibrated at 5 V. The provided accuracy is applicable for a supply voltage between 4.5 V and 5.5 V. The accuracy is smaller with a supply voltage between 2.97 V and 4.5 V. For applications where the best accuracy at 3 V is requested, ask for a custom specific, 3 V calibrated device. Other TSic products with custom specific calibrations are available upon request e.g. other temperature range for high accuracy. Accuracy at delivery; the assembly method can influence the accuracy!



Order Information - SOP-8

Output signal	Analog	Analog ratiometric	Digital, ZACWire
201/203/206	TSic 201 SOP-8	TSic 203 SOP-8	TSic 206 SOP-8
Order code	030.00038	030.00060	030.00005
301/303/306	TSic 301 SOP-8	TSic 303 SOP-8	TSic 306 SOP-8
Order code	030.00036	030.00024	030.00006

Order Information - TO92

201/203/206	TSic 201 TO92	TSic 203 TO92	TSic 206 TO92
Order code	030.00056	030.00095	030.00049
301/303/306	TSic 301 TO92	TSic 303 TO92	TSic 306 TO92
Order code	030.00047	030.00074	030.00044

Additional Electronics

	Document name:
LabKit	DTTSicLabKit_E

Additional Documents

	Document name:
Application Note:	ATTSic_E



Order Information

Temperature Sensor IC

Secondary reference

TSic

Accuracy

- 2 = ±0.5 °C at +80 °C range
- 3 = ±0.3 °C at +80 °C range
- 4 = not defined
- 5 = ±0.1 °C at +40 °C range (limited measuring range from -10 °C to +60 °C)
- 6 = not defined
- 7 = ±0.07 °C at +20 °C range (limited measuring range from -10 °C to +60 °C)

Bit size

- 0 = 11 bit
- 1 = 14 bit

Output signal

- 1 = analog 0 V to 1 V
- 3 = ratiometric 10 % to 90 % V_{dd}
- 6 = digital ZACWire

Housing

- SOP-8
- TO92

Special

E.g. „250 Hz“ for a high sampling rate or „-30/70“ for temperature and tolerance range

TSIC 3 0 6 TO92 -30/70



Innovative Sensor Technology IST AG, Stegrütistrasse 14, 9642 Ebnat-Kappel, Switzerland
Phone: +41 71 992 01 00 | Fax: +41 71 992 01 99 | Email: info@ist-ag.com | www.ist-ag.com

All mechanical dimensions are valid at 25 °C ambient temperature, if not differently indicated • All data except the mechanical dimensions only have information purposes and are not to be understood as assured characteristics • Technical changes without previous announcement as well as mistakes reserved • The information on this data sheet was examined carefully and will be accepted as correct; No liability in case of mistakes • Load with extreme values during a longer period can affect the reliability • The material contained herein may not be reproduced, adapted, merged, translated, stored, or used without the prior written consent of the copyright owner • Typing errors and mistakes reserved • Product specifications are subject to change without notice • All rights reserved



TSic LabKit for USB/Windows

Temperature Sensor IC

An effective Plug & Play development tool

Benefits & Characteristics

- Allows simultaneous display (up to 4 temperature signals in real time)
- Easy testing of TSic without programming microcontrollers
- Measurement interval selection and data recording
- User-friendly software for temperature data display and customer-specific sensor configurations
- Display of min., max. and average temperatures for each attached sensor
- Data recording in a text file (can be exported to other applications e.g. Excel)

Illustration



Technical Data

Compatible TSic sensors:	TSic206, TSic306, TSic506F, TSic716 (TO92 only)
PC system requirements:	Microsoft Windows 98, 2000, XP or 8.1; 200 MHz CPU; 64 MB RAM; 10 MB disk space; CDROM or DVD drive; USB interface
PC connection:	USB with 1 m (3 ft.) cable
Connector:	Molex 22-01-2035
LabKit includes:	USB adapter for up to four temperature sensors (USB cable included), sensor ICs with cable ¹⁾ , recorder data acquisition, display and recording software for PC/Windows ²⁾

¹⁾ For sensor combinations, see order code

²⁾ Installation in German only; running software both in German and English



Pin Assignment

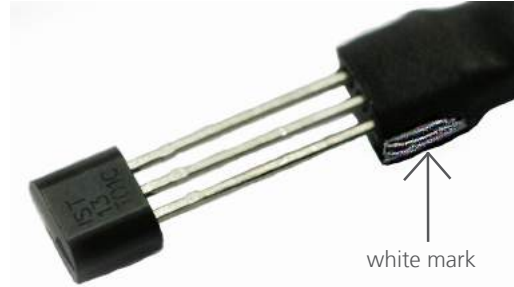
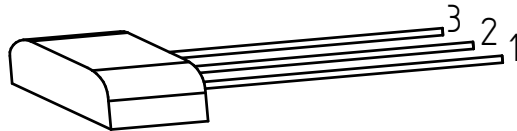

	Pin 1	Pin 2	Pin 3
TO92	GND (V_{SS})	Signal	V^+ (V_{DD}), supply voltage (3 V to 5.5 V)

Order Information

sensor ICs		
Order code	TSic LabKit für USB/Windows 030.00021	4 TSic 306 TO92
Order code	TSic LabKit für USB/Windows 030.00098	4 TSic 716 TO92
Order code	TSic LabKit für USB/Windows 030.00101	4 TSic 306 TO92 4 TSic 506F TO92
Order code	TSic LabKit für USB/Windows 030.00130	4 TSic 206 TO92
Order code	TSic LabKit für USB/Windows 030.00113	4 TSic 506F TO92
Order code	TSic LabKit für USB/Windows 030.00117	8 TSic 506F TO92
Order code	TSic LabKit für USB/Windows 030.00102	3 TSic 716 TO92 3 TSic 506F TO92

Additional Documents

	Document name:
Datasheet:	DTTSic20x_30x_E
Datasheet:	DTTSic50x_E
Datasheet:	DTTSic716_E
Application Note:	ATTSic_E



Innovative Sensor Technology IST AG, Stegrütistrasse 14, 9642 Ebnat-Kappel, Switzerland
Phone: +41 71 992 01 00 | Fax: +41 71 992 01 99 | Email: info@ist-ag.com | www.ist-ag.com

All mechanical dimensions are valid at 25 °C ambient temperature, if not differently indicated • All data except the mechanical dimensions only have information purposes and are not to be understood as assured characteristics • Technical changes without previous announcement as well as mistakes reserved • The information on this data sheet was examined carefully and will be accepted as correct; No liability in case of mistakes • Load with extreme values during a longer period can affect the reliability • The material contained herein may not be reproduced, adapted, merged, translated, stored, or used without the prior written consent of the copyright owner • Typing errors and mistakes reserved • Product specifications are subject to change without notice • All rights reserved

Application Note

Temperature Sensor IC



Application Note

Temperature Sensor IC

Content

1. TSic 206/203/201/306/316/303/301	8
2. TSic 506F/503F/516/501F	10
3. TSic 716	11
4. TSic Accuracy Overview ¹⁾	11
5. ZACwire™ Digital Output	11
6. Die and Package Specifications	17
7. TSic Block Diagram	20
8. Additional Documents	21



Application Note

Temperature Sensor IC

1. TSic 206/203/201/306/316/303/301

The TSic series of temperature sensor ICs are specifically designed as a low-power solution for temperature measurement in building automation, medical/pharma technologies, industrial and mobile applications. The TSic provides a simple temperature measurement and achieves outstanding accuracy combined with long term stability.

The TSic has a high precision bandgap reference with a PTAT (proportional-to-absolute-temperature) output, a low-power and high-precision ADC and an on-chip DSP core with an EEPROM for the precisely calibrated output signal. The TSic temperature sensor is fully calibrated, meaning no further calibration effort is required by the customer.

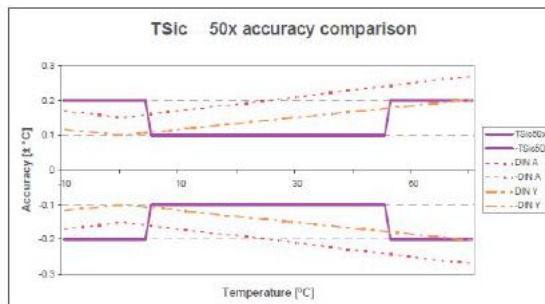

Figure 1: Comparison of TSic <-> platinum sensor accuracy

Extended long wires (> 10 m) will not influence the accuracy. The TSic is available with digital (ZacWire™, TSic x06), analog (0 V to 1V, TSic x01) or ratiometric (10 % to 90 % V⁺, TSic x03) output signal. The low power consumption of about 35 μA makes it suitable for many applications.

With an accuracy of ±0.3 K in a temperature range of 80 K (e.g. +10 °C to +90 °C), the TSic sensors are more accurate than a class F0.3 (IEC60751) platinum sensor. The tolerances of the TSic and F 0.3 and F 0.15 platinum sensors are compared in Figure 1. With a standard calibration, the TSic 30x is more accurate than a F 0.3 platinum sensor in the range of +10 °C to +110 °C. The range can be shifted up or downwards to reach a high accuracy between e.g. -30 °C to +50 °C.

Output examples	Temperature Range: -50 °C to +150 °C		
Temp (°C)	Digital Values (TSic x06)	Analog 0 V to 1 V (TSic x01)	Analog Ratiometric 10 % to 90 % (V ⁺ = 5.0 V) (TSic x03)
-50 ¹⁾	0x000	0.000	10 % V ⁺ (0.5 V)
-10	0x199	0.200	26 % V ⁺ (1.3 V)
0	0x200	0.250	30 % V ⁺ (1.5 V)
25	0x2FF	0.375	40 % V ⁺ (2.0 V)
60	0x465	0.550	54 % V ⁺ (2.7 V)
125	0x6FE	0.875	80 % V ⁺ (4.0 V)
150 ²⁾	0x7FF	1.000	90 % V ⁺ (4.5 V)

1) LT = -50 2) HT = 150 as standard value for the temperature calculation

Formulas for the output signal [°C]:

Analog output (0 V to 1 V):

$$T = \text{Sig [V]} \times (\text{HT} - \text{LT}) + \text{LT [°C]}$$

$$\frac{\text{Sig [V]} - 0.1}{\text{V}^+ \text{ [V]}}$$

Ratiometric output (10 % to 90 %):

$$T = \frac{\text{Digital signal}}{0.8} \times (\text{HT} - \text{LT}) + \text{LT [°C]}$$

Digital output - 11 bit:

$$T = \frac{\text{Digital signal}}{2047} \times (\text{HT} - \text{LT}) + \text{LT [°C]}$$

Digital output - 14 bit (TSic 316):

$$T = \frac{\text{Digital signal}}{16383} \times (\text{HT} - \text{LT}) + \text{LT [°C]}$$



LT: Lower temperature limit [= -50 °C] V+: Supply voltage [V]
HT: Higher temperature limit [= +150 °C] Sig[V]: Analog/ratiometric output signal [V]

2. TSic 506F/503F/516/501F

The TSic series of temperature sensor ICs are specifically designed as a low-power solution for temperature measurement in building automation, medical / pharma technologies, industrial and mobile applications. The TSic provides a simple temperature measurement and achieves outstanding accuracy combined with long term stability.

The TSic has a high precision bandgap reference with a PTAT (proportional-to-absolute-temperature) output, a low-power and high-precision ADC and an on-chip DSP core with an EEPROM for the precisely calibrated output signal.

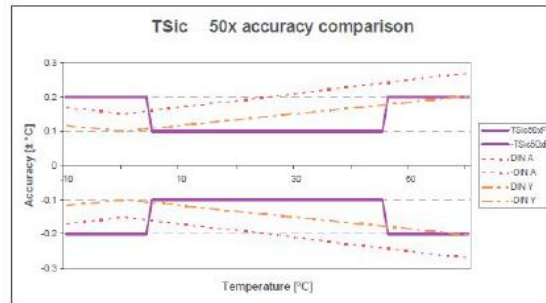

Figure 1: Comparison of TSic <-> platinum sensor accuracy

The TSic temperature sensor is fully calibrated, meaning no further calibration effort is required by the customer. With an accuracy of ±0.1 K in a range of 40 K (e.g. +5 °C to +45 °C), the sensor is more accurate than a class F0.1 (IEC 60751) platinum sensor. Extended long wires (> 10 m) will not influence the accuracy. The TSic is available with digital (ZacWire™, TSic 506F), analog (0 V to 1 V, TSic 501F) or ratiometric (10 % to 90 % V+, TSic 503F) output signal. The low power consumption of about 35 µA makes it suitable for many applications.

Output Examples		Temperature Range: -10 °C to +60 °C	
Temp (°C)	Digital Values (TSic x06)	Analog 0 V to 1 V (TSic x01)	Analog Ratiometric 10 % to 90 % (V+ = 5.0 V) (TSic x03)
< -10 to -10 ¹⁾	0x000	0.000	10 % V+ (0.5 V)
0	0x124	0.143	21.4 % V+ (1.07 V)
25	0x3FF	0.500	50 % V+ (2.5 V)
+60 ²⁾ to > +60	0x7FF	1.000	90 % V+ (4.5 V)

1) LT = -10

2) HT = 60 as standard value for the temperature calculation

Formulas for the output signal [°C]:

Analog output (0 V to 1 V):

$$T = \text{Sig [V]} \times (\text{HT} - \text{LT}) + \text{LT [°C]}$$

Ratiometric output (10 % to 90 %):

$$T = \frac{\frac{\text{Sig [V]}}{\text{V+ [V]} - 0.1}}{0.8}} \times (\text{HT} - \text{LT}) + \text{LT [°C]}$$

Digital output - 11 bit:

$$T = \frac{\text{Digital signal}}{2047}} \times (\text{HT} - \text{LT}) + \text{LT [°C]}$$

Digital output - 14 bit (TSic 516):

$$T = \frac{\text{Digital signal}}{16383}} \times (\text{HT} - \text{LT}) + \text{LT [°C]}$$

LT: Lower temperature limit [= -10 °C]
HT: Higher temperature limit [= +60 °C]

V+: Supply voltage [V]
Sig[V]: Analog/ratiometric output signal [V]



3. TSic 716

The TSic series of temperature sensor ICs are specifically designed as a low-power solution for temperature measurement in building automation, medical/pharma technologies, industrial and mobile applications. The TSic provides a simple temperature measurement and achieves outstanding accuracy combined with long term stability.

The TSic has a high precision bandgap reference with a PTAT (proportional-to-absolute-temperature) output, a low-power and high-precision ADC and an on-chip DSP core with an EEPROM for the precisely calibrated output signal. The IST AG TSic sensor is fully tested and calibrated to ensure the guaranteed accuracy.

Output Examples	Temperature Range: -10 °C to +60 °C
Temp (°C)	Digital
+35	0x2925
+40	0x2DB7
+45	0x3249

Formulas for the output signal [°C]:

Digital output:
$$T = \frac{\text{Digital signal}}{16383} \times (HT - LT) + LT \text{ [}^\circ\text{C]}$$

- LT: Lower temperature limit [= -10 °C]
- HT: Higher temperature limit [= +60 °C]
- V⁺: Supply voltage [V]

4. TSic Accuracy Overview¹⁾

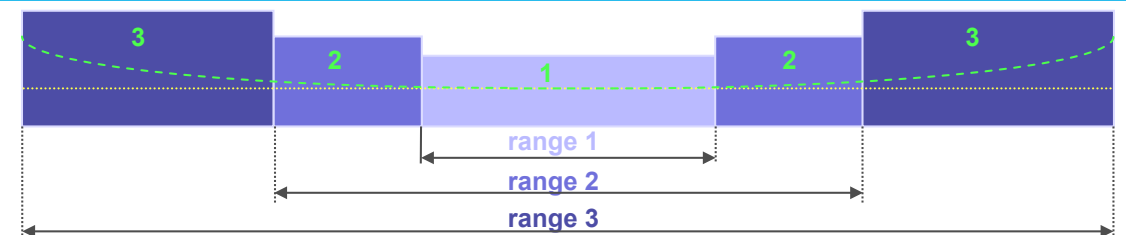

Product	Resolution	Range 1	Accuracy 1	Range 2	Accuracy 2	Range 3	Accuracy 3
TSic 20x	0.1 °C	+10 °C to +90 °C	±0.5 °C	-20 °C to +110 °C	±1 °C	-50 °C to +150 °C	±2 °C
TSic 30x	0.1 °C	+10 °C to +90 °C	±0.3 °C	-20 °C to +110 °C	±0.6 °C	-50 °C to +150 °C	±1.2 °C
TSic 50x	0.034 °C	+5 °C to +45 °C	±0.1 °C	-	-	-10 °C to +60 °C	±0.2 °C
TSic 716	0.004 °C	+25 °C to +45 °C	±0.07 °C	-	-	-10 °C to +60 °C	±0.2 °C

¹⁾ Range 1 can be shifted to a customer specific temperature

5. ZACwire™ Digital Output

5.1 TSic ZACwire™ Communication Protocol

ZACwire™ is a single wire bi-directional communication protocol. The bit encoding is similar to Manchester in that clocking information is embedded into the signal (falling edges of the signal happen at regular periods). This allows the protocol to be largely insensitive to baud rate differences between the two ICs communicating. In end-user applications, the TSic will be transmitting temperature information, and another IC in the system (most likely a µController) will be reading the temperature data over the ZACwire™.



5.2 Temperature Transmission Packet from a TSic

The TSic transmits 1-byte packets. These packets consist of a start bit, 8 data bits, and a parity bit. The nominal baud rate is 8 kHz (125 μ sec bit window). The signal is normally high. When a transmission occurs, the start bit occurs first followed by the data bits (MSB first, LSB last). The packet ends with an even parity bit.

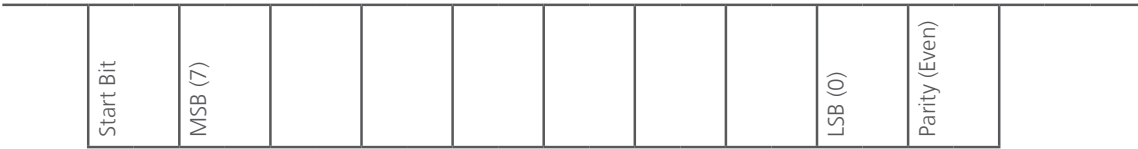

Figure 1.1 – ZACwire™ Transmission Packet

The TSic provides temperature data with 11-bit or 14-bit resolution, and obviously these 11 bits or 14-bit of information cannot be conveyed in a single packet. A complete temperature transmission from the TSic consists of two packets. The first packet contains the most significant 3 bits or 6 bits of temperature information, and the second packet contains the least significant 8 bits of temperature information. There is a single bit window of high signal (stop bit) between the end of the first transmission and the start of the second transmission.

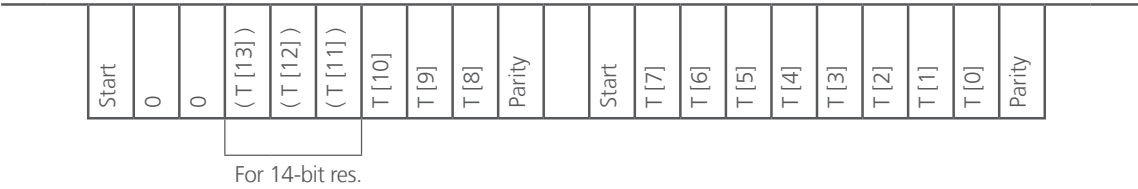
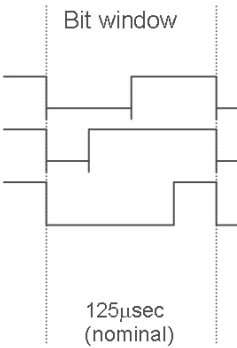

Figure 1.2 – Full ZACwire™ Temperature Transmission from TSic

5.3 Bit Encoding

The bit format is duty cycle encoded:

- Start bit => 50 % duty cycle used to set up strobe time
- Logic 1 => 75 % duty cycle
- Logic 0 => 25 % duty cycle



Perhaps the best way to show the bit encoding is with an oscilloscope trace of a ZACwire™ transmission. The following shows a single packet of 96 Hex being transmitted. Because 96 Hex is already even parity, the parity bit is zero.

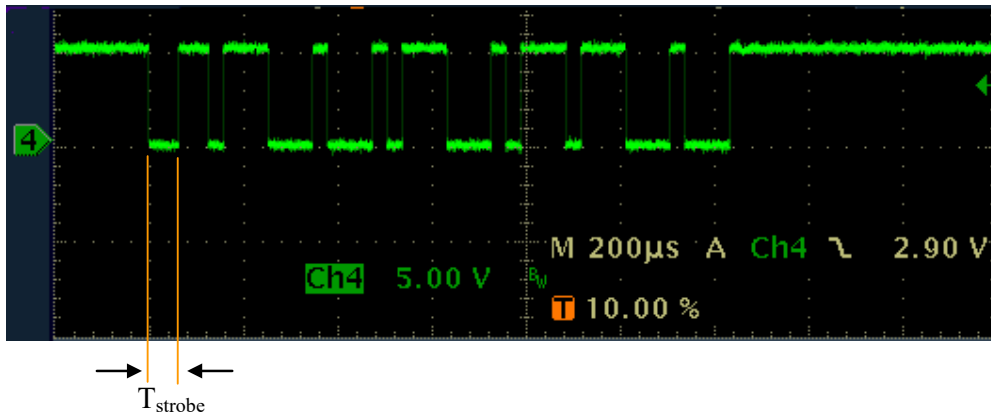

Figure 1.3 – ZACwire™ Transmission

5.4 How to Read a Packet

When the falling edge of the start bit occurs, measure the time until the rising edge of the start bit. This time (T_{strobe}) is the strobe time. When the next falling edge occurs, wait for a time period equal to T_{strobe} and then sample the ZACwire™ signal. The data present on the signal at this time is the bit being transmitted. Because every bit starts with a falling edge, the sampling window is reset with every bit transmission. This means errors will not accrue for bits downstream from the start bit, as it would with a protocol such as RS232. It is recommended, however, that the sampling rate of the ZACwire™ signal when acquiring the start bit be at least 16x the nominal baud rate. Because the nominal baud rate is 8 kHz, a 128 kHz sampling rate is recommended when acquiring T_{strobe} .

5.5 How to Read a Packet using a μ Controller

It is best to connect the ZACwire™ signal to a pin of the μ Controller that is capable of causing an interrupt on a falling edge. When the falling edge of the start bit occurs, it causes the μ Controller to branch to its ISR. The ISR enters a counting loop incrementing a memory location (T_{strobe}) until it sees a rise on the ZACwire™ signal. When T_{strobe} has been acquired, the ISR can simply wait for the next 9 falling edges (8-data, 1-parity). After each falling edge, it waits for T_{strobe} to expire and then sample the next bit.

The ZACwire™ line is driven by a strong CMOS push/pull driver. The parity bit is intended for use when the ZACwire™ is driving long (> 2 m) interconnects to the μ Controller in a noisy environment. For systems in which the “noise environment is more friendly”, the user can choose to have the μ Controller ignore the parity bit. In the appendix of this document is sample code for reading a TSic ZACwire™ transmission using a PIC16F627 μ Controller.

5.6 How Often Does the TSic Transmit?

If the TSic is being read via an ISR, how often is it interrupting the μ Controller with data? The update rate of the TSic can be programmed to one of 4 different settings: 250 Hz, 10 Hz, 1 Hz, and 0.1 Hz. This is done during calibration of the sensor on IST AG side. The standard update rate is 10 Hz (TSic 206, TSic 306, TSic 506) or 1 Hz (TSic 716). For other update rates please contact IST AG. Servicing a temperature-read ISR requires about 2.7 ms. If the update rate of the TSic is programmed to 250 Hz, then the μ Controller spends about 66 % of its time reading the temperature transmissions. If, however, the update rate is programmed to something more reasonable like 1 Hz, then the μ Controller spends about 0.27 % of its time reading the temperature transmissions.



5.7 Solutions if Real Time System Cannot Tolerate the TSic Interrupting the μ Controller

Some real time systems cannot tolerate the TSic interrupting the μ Controller. The μ Controller must initiate the temperature read. This can be accomplished by using another pin of the μ Controller to supply V_{DD} to the TSic. The TSic will transmit its first temperature reading approximately 65-85 ms ¹⁾ (@RT) after power up. When the μ Controller wants to read the temperature, it first powers the TSic using one of its port pins. It will receive a temperature transmission approximately 65 ms to 85 ms later. If during that 85 ms, a higher priority interrupt occurs, the μ Controller can simply power down the TSic to ensure it will not cause an interrupt or be in the middle of a transmission when the high priority ISR finishes. This method of powering the TSic has the additional benefit of acting like a power down mode and reducing the quiescent current from a nominal 45 μ A to zero. The TSic is a mixed signal IC and provides best performance with a clean V_{DD} supply. Powering through a μ Controller pin does subject it to the digital noise present on the μ Controller's power supply. Therefore it is best to use a simple RC filter when powering the TSic with a μ Controller port pin. See the diagram below

1) This value is depending on the temperature. In lower temperatures this value can be lower too

μ Controller powers TSic with a port pin through a simple RC filter.

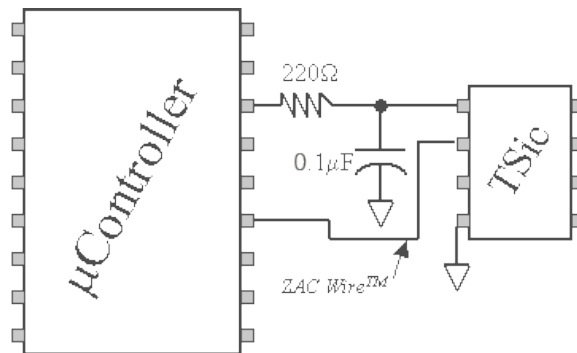

5.8 Appendix A: An Example of PIC1 Assembly Code for Reading the ZACwire™

In the following code example, it is assumed that the ZACwire™ pin is connected to the interrupt pin (PORTB, 0) of the PIC and that the interrupt is configured for falling edge interruption.

This code should work for a PIC running between 2 MHz to 12 MHz.

```
TEMP_HIGH EQU 0X24 ;; MEMORY LOCATION RESERVED FOR TEMP HIGH BYTE
TEMP_LOW EQU 0X25 ;; MEMORY LOCATION RESERVED FOR TEMP LOW BYTE
;; THIS BYTE MUST BE CONSECUTIVE FROM TEMP_HIGH
LAST_LOC EQU 0X26 ;; THIS BYTE MUST BE CONSECUTIVE FROM TEMP_LOW
TSTROBE EQU 0X26 ;; LOCATION TO STORE START BIT STROBE TIME
ORG 0X004 ;; ISR LOCATION
```

.....

CODE TO SAVE ANY NEEDED STATE AND TO DETERMINE THE SOURCE OF THE ISR GOES HERE. ONCE YOU HAVE DETERMINED THE SOURCE IF THE INTERRUPT WAS A ZAC WIRE TRANSMISSION THEN YOU BRANCH TO ZAC_TX

.....

```
ZAC_TX: MOV LW TEMP_HIGH ;; MOVE ADDRESS OF TEMP_HIGH (0X24) TO W REG
MOV W FSR ;; FSR = INDIRECT POINTER, NOW POINTING TO TEMP_HIGH
GET_TLOW: MOV LW 0X02 ;; START TSTROBE COUNTER AT 02 TO ACCOUNT FOR
MOV W TSTROBE ;; OVERHEAD IN GETTING TO THIS POINT OF ISR
CLRF INDF ;; CLEAR THE MEMORY LOCATION POINTED TO BY FS
```



```

STRB:      INCF    TSTROBE,1      ;; INCREMENT TSTROBE
           BTFSC  STATUS,Z      ;; IF TSTROBE OVERFLOWED TO ZERO THEN
           GOTO   RTI           ;; SOMETHING WRONG AND RETURN FROM INTERRUPT
           BTFSS  PORTB,0       ;; LOOK FOR RISE ON ZAC WIRE
           GOTO   STRB          ;; IF RISE HAS NOT YET HAPPENED INCREMENT TSTROBE

BIT_LOOP:  CLRF    BIT_CNT       ;; MEMORY LOCATION USED AS BIT COUNTER
           CLRF   STRB_CNT      ;; MEMORY LOCATION USED AS STROBE COUNTER
           CLRF   TIME_OUT     ;; MEMORY LOCATION USED FOR EDGE TIME OUT

WAIT_FALL: BTFSS  PORTB,0       ;; WAIT FOR FALL OF ZAC WIRE
           GOTO   PAUSE_STRB    ;; NEXT FALLING EDGE OCCURRED
           INCFSZ TIME_OUT,1    ;; CHECK IF EDGE TIME OUT COUNTER OVERFLOWED
           GOTO   WAIT_FALL     ;;
           GOTO   RTI           ;; EDGE TIME OUT OCCURRED

PAUSE_STRB: INCF    STRB_CNT,1   ;; INCREMENT THE STROBE COUNTER
           MOVF   TSTROBE,0     ;; MOVE TSTROBE TO W REG
           SUBWF  STRB_CNT,0    ;; COMPARE STRB_CNT TO TSTROBE
           BTFSS  STATUS,Z      ;; IF EQUAL THEN IT IS TIME TO STROBE
           GOTO   PAUSE_STRB    ;; ZAC WIRE FOR DATA, OTHERWISE KEEP COUNTING
           ;; LENGTH OF THIS LOOP IS 6-STATES. THIS HAS TO
           ;; MATCH THE LENGTH OF THE LOOP THAT ACQUIRED TSTROBE
           BCF    STATUS,C      ;; CLEAR THE CARRY
           BTFSC  PORTB,0       ;; SAMPLE THE ZAC WIRE INPUT
           BSF    STATUS,C      ;; IF ZAC WIRE WAS HIGH THEN SET THE CARRY
           RLF    INDF,1        ;; ROTATE CARRY=ZAC WIRE INTO LSB OF REGISTER
           ;; THAT FSR CURRENTLY POINTS TO
           CLRF   TIME_OUT     ;; CLEAR THE EDGE TIMEOUT COUN

WAIT_RISE: BTFSC  PORTB,0       ;; IF RISE HAS OCCURRED THEN WE ARE DONE
           GOTO   NEXT_BIT
           INCFSZ TIME_OUT,1    ;; INCREMENT THE EDGE TIME OUT COUNTER
           GOTO   WAIT_RISE
           GOTO   RTI           ;; EDGE TIME OUT OCCURRED.

NEXT_BIT:  INCF    BIT_CNT,1    ;; INCREMENT BIT COUNTER
           MOVLW  0X08         ;; THERE ARE 8-BITS OF DATA
           SUBWF  BIT_CNT,0    ;; TEST IF BIT COUNTER AT LIMIT
           BTFSS  STATUS,Z      ;; IF NOT ZERO THEN GET NEXT BIT
           GOTO   BIT_LOOP

WAIT_PF:   CLRF    TIME_OUT     ;; CLEAR THE EDGE TIME OUT COUNTER
           BTFSS  PORTB,0       ;; WAIT FOR FALL OF PARITY
           GOTO   P_RISE
           INCFSZ TIME_OUT,1    ;; INCREMENT TIME_OUT COUNTER
           GOTO   WAIT_PF
           GOTO   RTI           ;; EDGE TIMEOUT OCCURRED

P_RISE:    CLRF    TIME_OUT     ;; CLEAR THE EDGE TIME OUT COUNTER
WAIT_PR:   BTFSC  PORTB,0       ;; WAIT FOR RISE OF PARITY
           GOTO   NEXT_BYTE
           INCFSZ TIME_OUT,1    ;; INCREMENT EDGE TIME OUT COUNTER
           GOTO   WAIT_PR
           GOTO   RTI           ;; EDGE TIME OUT OCCURRED
  
```



```

NEXT_BYTE:   INCF   FSR,1           ;; INCREMENT THE INDF POINTER
              MOVLW LAST_LOC
              SUBWF FSR,0         ;; COMPARE FSR TO LAST_LOC
              BTFSS STATUS,Z     ;; IF EQUAL THEN DONE
              GOTO   WAIT_TLOW
    
```

```

.....
;; IF HERE YOU ARE DONE READING THE ZAC WIRE AND HAVE THE DATA ;;
;; IN TEMP_HIGH & TEMP_LOW                                     ;;
.....
    
```

```

WAIT_TLOW:   CLRF   TIME_OUT
WAIT_TLF:    BTFSS  PORTB,0       ; WAIT FOR FALL OF PORTB,0 INDICATING
              GOTO  GET_TLOW     ; START OF TEMP LOW BYTE
              INCF  TIME_OUT
              GOTO  WAIT_TLF
              GOTO  RTI          ; EDGE TIMEOUT OCCURRED
    
```

```

RTI:         .....
              ;; RESTORE ANY STATE SAVED OFF AT BEGINNING OF ISR ;;
              .....
              BCF   INTCON,INTF  ;; CLEAR INTERRUPT FLAG
              BSF   INTCON,INTE  ;; ENSURE INTERRUPT RE-ENABLED
              RETFIE             ;; RETURN FROM INTERRUPT
    
```



6. Die and Package Specifications

6.1 SOP-8

The following dimensional drawings are for the TSic Series SOP-8 (SOIC Narrow, 0.150) package. See Table 1.1 and Table 1.2 on the next page for the dimensions labeled in these diagrams. Unless specified otherwise, dimensions are in inches.

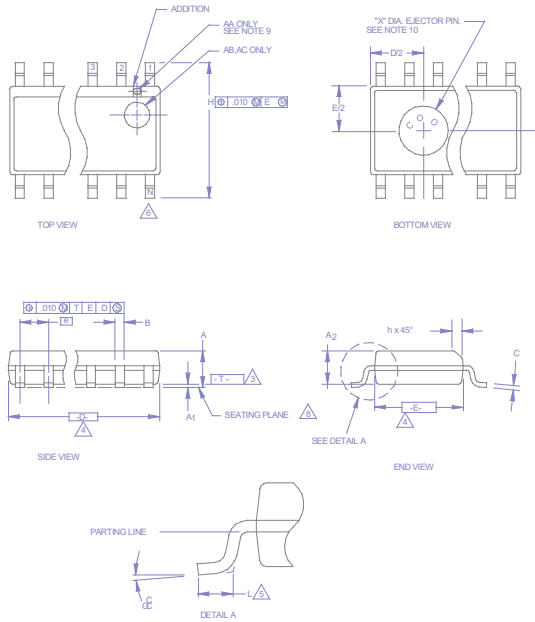

Notes:

- Maximum thickness allowed is 0.015
- Dimensioning and tolerances:

Decimal	Angular	3rd Angle Projection
.xx ±0.01"	±1 °C	
.xxx ±0.002"		
.xxxx ±0.0010"		
- "T" is a reference datum
- "D" & "E" are reference datums and do not include mold flash or protrusions but do include mold mismatch and are measured at the mold parting line. Mold flash and protrusions do not exceed 0.006 inches at the end and 0.01 " at the window
- "L" is the length of the terminal for soldering to a substrate
- "N" is the number of terminal positions
- Terminal positions are shown for reference only
- Formed leads are planar with respect to one another within 0.03 " at the seating plane
- The appearance of the pin 1 marker is optionally either the round type or the rectangular type
- Country of origin location on package bottom is optional and depends on assembly location
- Controlling dimension: Inches
- This part is compliant with JEDEC Standard MS-012, Variation AA, AB & AC

6.1.1 SOP-8 Pin Assignment

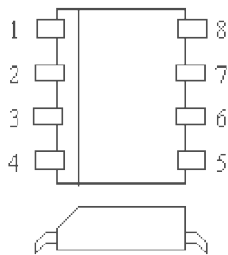

Pin	Name	Description
1	V+	Supply voltage (3 V to 5.5 V)
2	Signal	Temperature output signal
4	Gnd	Ground
3,5-8	TP/NC	Test pin / NC Do not connect



6.1.2 Inches

	Common Dimensions			Note	Variations	3			S
	MIN	NOM	MAX			D	MIN	NOM	
A	0.061	0.064	0.068		AA	0.189	0.194	0.196	8
A1	0.004	0.006	0.0098		AB	0.337	0.342	0.344	14
A2	0.055	0.058	0.061		AC	0.386	0.391	0.393	16
B	0.0138	0.016	0.0192						
C	0.0075	0.008	0.0098						
D	See variations				3				
E	0.15	0.155	0.0157						
e	0.050 BSC								
H	0.23	0.236	0.244						
h	0.01	0.013	0.016						
L	0.016	0.25	0.035						
N	See variations				5				
	0°	5°	ε						
X	0.085	0.093	C						

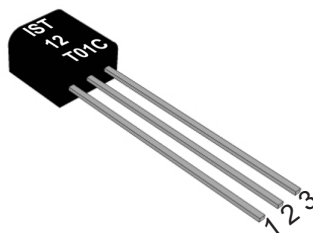

6.1.3 Millimeters

	Common Dimension			Note	Variations	3			S
	MIN	NOM	MAX			D	MIN	NOM	
A	1.55	1.63	1.73		AA	4.8	4.93	4.98	8
A1	0.127	0.15	0.25		AB	8.58	8.69	8.74	14
A2	1.4	1.47	1.55		AC	9.8	9.93	9.98	16
B	0.35	0.41	0.49						
C	0.19	0.2	0.25						
D	See variations				3				
E	3.81	3.94	3.99						
e	1.27 BSC								
H	5.84	5.99	6.2						
h	0.25	0.33	0.41						
L	0.41	0.64	0.89						
N	See variations				5				
	0°	5°	8°						
X	2.16	2.36	2.54						



6.2 TO92

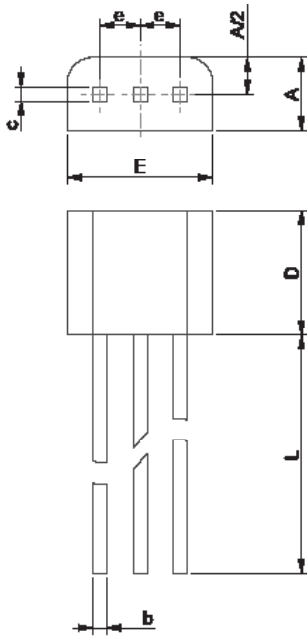

Dimensions	Millimeters		Inches	
	MIN	MAX	MIN	MAX
A	2.16	2.41	0.085	0.095
b	0.41	0.495	0.016	0.0195
c	0.41	0.495	0.016	0.0195
D	3.61	4.01	0.14	0.16
E	4.37	4.77	0.172	0.188
e	NOM. 1.27		NOM. 0.05	
L	13	13.97	0.512	0.550

6.2.1 TO92 Pin Assignment

Pin	Name	Description
3	V ⁺ (V _{DD})	Supply Voltage (3 V to 5.5 V)
2	Signal	Temperature Output Signal
1	Gnd (V _{SS})	Ground

6.3 Bare Die

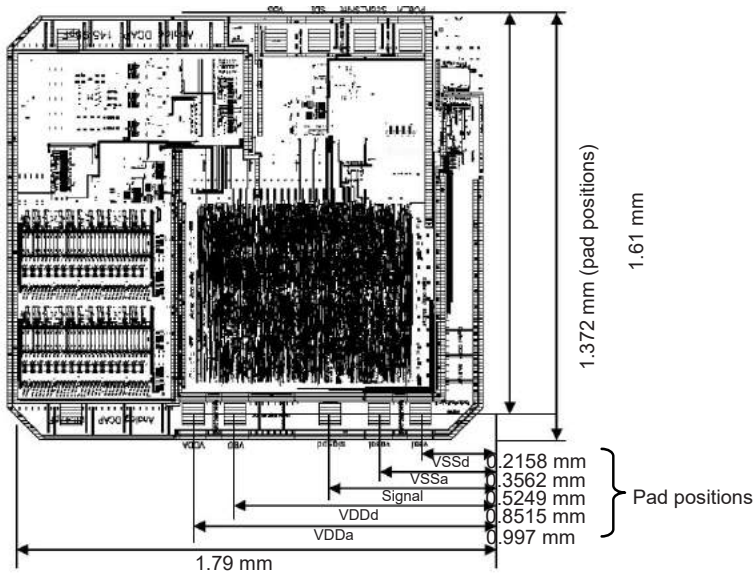



6.3.1 Bare Die Pin Assignment

Pin	Name	Description
3	V ⁺ (V _{DD})	Supply Voltage (3 V to 5.5 V)
2	Signal	Temperature Output Signal
1	Gnd (V _{SS})	Ground

Die Thickness: 390 μm
Pad size: 68 μm x 68 μm

The analog and digital power and ground of the chip are wired to same substrate or Flex-Pad: V_{DDA} and V_{DD} are wired to V_{DD}⁺ and V_{SSA} and V_{SS} are wired to Ground. The Signal pin needs only one wire.

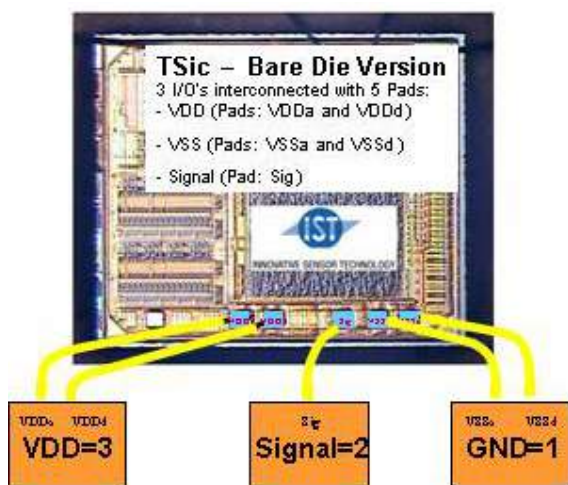

7. TSic Block Diagram

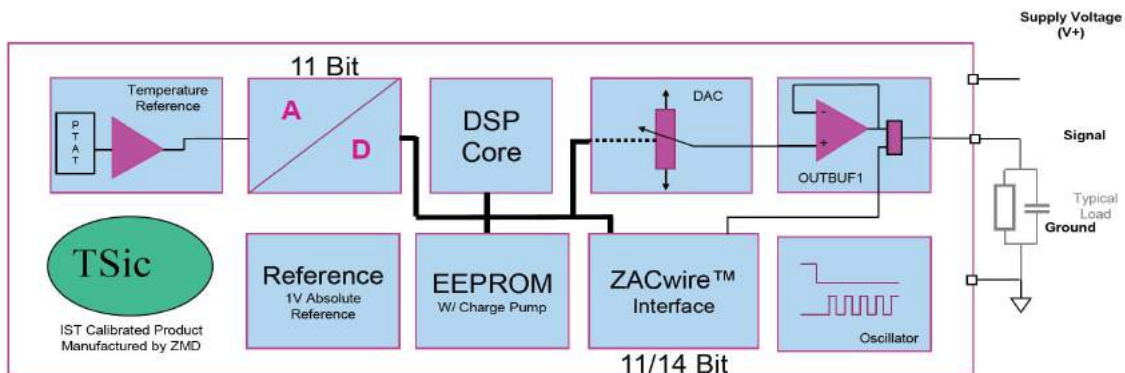



8. Additional Documents

	Document name:	
Data Sheet:	DTTSic20x_30x_E	DTTSic20x_30x_D
	DTTSic50x_E	DTTSic50x_D
	DTTSic716_E	DTTSic716_D
LabKit:	DTTSicLabKit_E	DTTSicLabKit_D



Innovative Sensor Technology IST AG, Stegrütistrasse 14, 9642 Ebnat-Kappel, Switzerland
Phone: +41 71 992 01 00 | Fax: +41 71 992 01 99 | Email: info@ist-ag.com | www.ist-ag.com

All mechanical dimensions are valid at 25 °C ambient temperature, if not differently indicated • All data except the mechanical dimensions only have information purposes and are not to be understood as assured characteristics • Technical changes without previous announcement as well as mistakes reserved • The information on this data sheet was examined carefully and will be accepted as correct; No liability in case of mistakes • Load with extreme values during a longer period can affect the reliability • The material contained herein may not be reproduced, adapted, merged, translated, stored, or used without the prior written consent of the copyright owner • Typing errors and mistakes reserved • Product specifications are subject to change without notice • All rights reserved